

**Recommended Standard Specification
For
Winches Used With
Synthetic Web Tie Downs**

WSTDA-T-3



©2007 Web Sling & Tie Down Association

© Web Sling & Tie Down Association. All rights reserved. No part of this publication may be produced, stored in a retrieval system, or transmitted, in any form or by any means, electronic, mechanical, photocopying, recording or otherwise, without the prior permission of the Web Sling & Tie Down Association. This publication is circulated subject to the condition that it shall not, by way of trade or otherwise, be lent, sold, hired out or otherwise circulated without WSTDA's prior consent.

This recommended standard specification has been formulated as a guide to users, manufacturers, industry and government to insure the proper design, testing, inspection, operation and maintenance of Winches Used With Synthetic Web Tie Down assemblies. The existence of this recommended standard specification does not, however, prevent members of the Web Sling & Tie Down Association, Inc. and other manufacturers from manufacturing or selling products not conforming to the standards.

FOREWORD

This Recommended Standard Specification applies to winches designed to accommodate synthetic web tie downs for the purpose of securing cargo. This standard recommends construction as well as identification and marking of these winches. In addition, it gives important practical advice on the use, maintenance and inspection of these winches.

The exclusion from this Recommended Standard Specification of winches designed to accommodate synthetic web tie downs of different materials and capacities is not intended to preclude their use and shall not be interpreted in this manner.

Winches made from materials or construction other than those detailed in this Recommended Standard Specification shall be used in accordance with the recommendations of the winch manufacturer or qualified person. The specifications contained in this Recommended Standard Specification for Winches used with Synthetic Web Tie Downs were compiled under the auspices of the Web Sling & Tie Down Association, Inc. This Recommended Standard Specification is intended to assist users in specifying the proper winch for their particular requirements. To serve as a guide to the industry in the construction and use of winches, and to serve as a guide to governmental and other regulatory bodies responsible for the proper use and inspection of winches used with synthetic web tie downs.

Safety is the paramount consideration involved in the use of any winch designed to accommodate synthetic web tie downs for the purpose of securing cargo. This standard does not purport to address all safety concerns, if any, associated with its use. It is the responsibility of the user of this standard to establish appropriate safety and health practices and determine the applicability of the regulatory limitations prior to use. The appropriate winch shall be selected by the user for their specific application. Users of winches designed to accommodate synthetic web tie downs for the purpose of securing cargo shall have knowledge on the proper method of cargo securement. Also users shall be knowledgeable about federal, state, provincial, local and industry regulations applicable to cargo securement.

MANDATORY AND ADVISORY RULES

Mandatory rules of this standard are characterized by the use of the word "shall." If a rule is of the advisory nature, it is indicated by the use of the word "should," or it is stated as a recommendation.

WEB SLING & TIE DOWN ASSOCIATION, INC.

2105 Laurel Bush Road, Suite 200
Bel Air, Maryland 21015

Phone (443) 640-1070

Fax (443) 640-1031

Email: wstda@ksgroup.org

Website: www.wstda.com



First Published and Copyright 1998

First Revision 2007

This Standard is available through the WSTDA. Reproduction is not permitted



Contents

Chapter	1.0	TERMINOLOGY & DEFINITIONS	
Section	1.1	Purpose.....	1
Section	1.2	Configuration of Web Winches.....	1
Section	1.3	Definition of Terms.....	2
Chapter	2.0	CONSTRUCTION OF WINCHES	
Section	2.1	Purpose.....	3
Section	2.2	Winch Components.....	3
Section	2.3	Design Factor.....	4
Section	2.4	Rated Capacities.....	4
Section	2.5	Identification / Marking Requirements.....	4
Chapter	3.0	STANDARD PROCEDURES FOR TESTING WINCHES	
Section	3.1	Purpose.....	4
Section	3.2	Type of Tests.....	4
Section	3.3	Test Procedures To Determine Breaking Strength.....	5
Chapter	4.0	RECOMMENDED OPERATING PRACTICES	
Section	4.1	Purpose.....	7
Section	4.2	Proper Selection.....	7
Section	4.3	Use And Care.....	7
Section	4.4	Environmental Considerations.....	8
Section	4.5	Inspection.....	8
Section	4.6	Inspection Records.....	8
Section	4.7	Removal From Service.....	9
Section	4.8	Repair of Winches.....	9

CHAPTER 1.0

TERMINOLOGY AND DEFINITIONS

SECTION 1.1 PURPOSE

1.1.1 This chapter provides a description of winches designed to accommodate synthetic web tie downs for the purpose of securing cargo and definitions that apply to such winches.

SECTION 1.2 CONFIGURATION OF WEB WINCHES

1.2.1 **SIDE MOUNT** - designed to be located on an outward facing surface of a vehicle

1.2.1.1 Weld-On / Bolt-On - Permanently mounted outward in a fixed position on the side, front or rear frame of the vehicle.

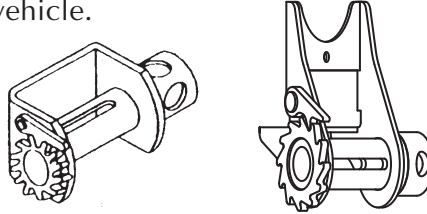

1.2.1.2 Portable - Flexible outward mounting to the side, front or rear frame is accomplished with a bracket that may contain one or two set screws.

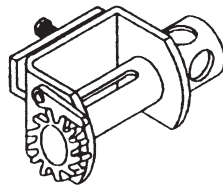

1.2.2 **UNDER MOUNT** - designed to be mounted beneath the vehicle.

1.2.2.1 Weld-On / Bolt-On - Permanently mounted in a fixed position on the bottom frame of the vehicle.

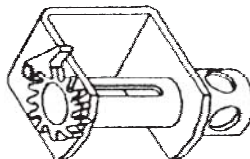

1.2.2.2 Portable - Flexible bottom mounting is accomplished with a bracket and one or two set screws.

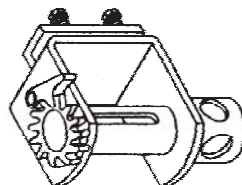

1.2.3 **SLIDING** - Designed to slide along the length of the vehicle to a desired location along the track or rail.

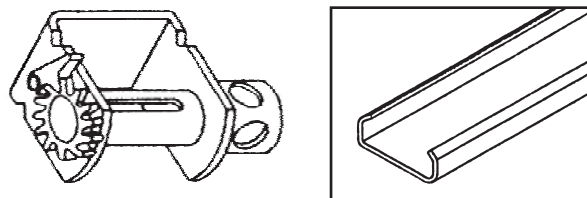

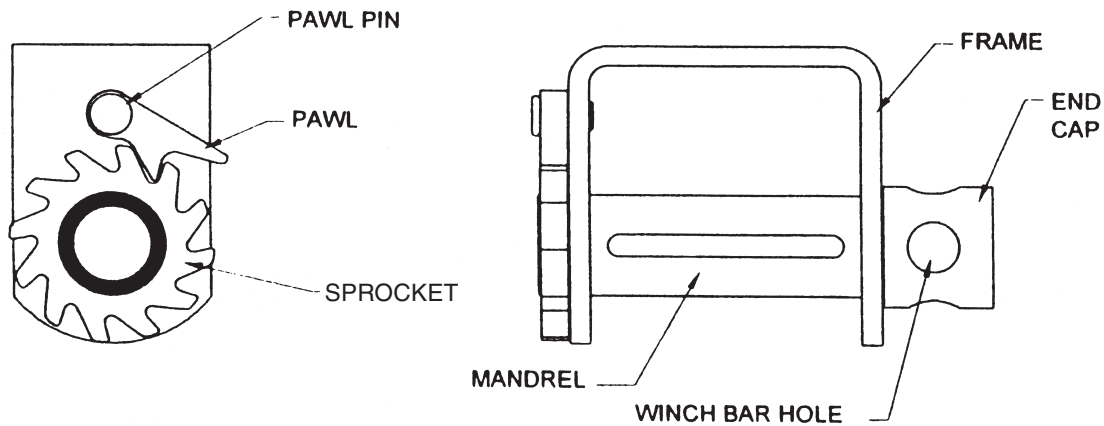

Figure 1

SECTION 1.3 DEFINITION OF TERMS

BREAKING STRENGTH - The load in pounds or kilograms at which point any load bearing part of the winch fails.

DEFORMATION - Visible damage, distortion or misshaping of any of a winch component.

DESIGN FACTOR - The ratio of the breaking strength to the working load limit (WLL) for each winch.

DESIGNATED PERSONNEL - Selected or assigned by the employer or employer's representative as being competent to perform specific duties.

END CAP - A sleeve containing a minimum of two (2) holes, 180 degrees apart on one or both ends of the mandrel to accommodate a winch bar.

FAILURE - A breakdown in any winch component whereby additional load may not be applied.

FRAME - The base structure that supports the other winch components. See Figure 1.

MANDREL - The component of the winch into which the webbing is inserted for tensioning the synthetic web tie down. See Figure 1.

PAWL - The component that locks and releases the winch sprocket. See Figure 1.

PAWL PIN - A fastener that attaches the pawl to the frame. See Figure 1.

SPROCKET - A gear that is attached to the mandrel that is engaged and locked by the pawl. See Figure 1.

SYNTHETIC WEBBING - A fabric, woven of high tenacity synthetic yarns, offering suitable characteristics for use in the manufacture of synthetic web tie downs. Reference the WSTDA Recommended Standard Specification for Synthetic Webbing used for Tie Downs WSTDA-T-4.

TENSILE LOAD - The force being applied expressed in pounds or kilograms.

SYNTHETIC WEB TIE DOWN - An assembly fabricated of synthetic webbing, with or without hardware, for the purpose of securing cargo. Reference the WSTDA Recommended Standard Specification for Synthetic Web Tie Downs WSTDA-T-1.

VEHICLE - Any conveyance for carrying goods or equipment, such as a truck, trailer, van or otherwise.

WINCH - A tensioning device, which is mounted directly to a vehicle for tensioning synthetic web tie downs used to secure cargo.

WINCH BAR - A lever designed to fit into the end cap that provides leverage to tension or release the synthetic web tie down assembly.

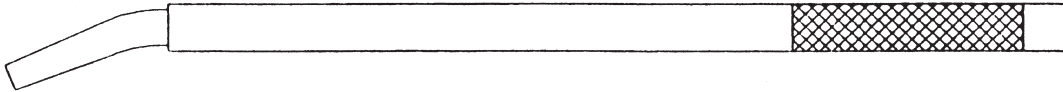

WORKING LOAD LIMIT (WLL) - The maximum allowable load assigned to each winch by the manufacturer which is not to exceed one-third of the winch breaking strength.

WRAP - One revolution of the load bearing portion of the webbing around the mandrel.

CHAPTER 2.0

CONSTRUCTION OF WINCHES

SECTION 2.1 PURPOSE

2.1.1 This chapter provides an outline of materials and construction characteristics of winches designed to accommodate synthetic web tie downs for the purpose of securing cargo.

SECTION 2.2 WINCH COMPONENTS

- 2.2.1 Winch components are normally fabricated from steel plate and then welded together to form a winch. Other materials, such as aluminum and stainless steel are utilized, as well as alternate assembly techniques that do not involve welding.
- 2.2.2 Basic winch components consist of an end cap, frame, sprocket, mandrel, pawl and pawl pin.
- 2.2.3 The end cap is most often fabricated from steel tubing and then fitted tightly over the end of the mandrel.
- 2.2.4 A typical winch frame is made from steel plate and undergoes a stamping process that creates two holes through which the mandrel fits and a smaller hole for the pawl pin. The frame is then bent into its 'U' shape.
- 2.2.5 The sprocket is attached to the mandrel and shall be positioned to ensure proper alignment and fit with the pawl.
- 2.2.6 The mandrel is most often fabricated from steel and contains slots to accommodate the synthetic web tie down. The slots shall be fabricated with smooth edges to prevent inadvertent cutting of the synthetic web tie downs.

- 2.2.7 The pawl shall be properly aligned and fitted with the sprocket to ensure the contact points are maximized and is free-floating and pivots into the sprocket by gravity.
- 2.2.8 The pawl pin is a fastener of sufficient strength that retains the pawl to the frame.
- 2.2.9 Winches should be coated to prevent corrosion.

SECTION 2.3 DESIGN FACTOR

WARNING
Never exceed the working load limit (WLL) of any winch. The loading of any winch beyond its WLL can result in severe personal injury or death. The winch design factor is based on destructive; laboratory controlled testing conditions, which will not be exactly duplicated during actual loading conditions.

- 2.3.1 The design factor for winches shall be a minimum of three (3) when tested in accordance with Chapter 3 of this Standard Specification.

SECTION 2.4 RATED CAPACITIES

- 2.4.1 The working load limit (WLL) of a winch shall be on one-third (1/3) of the breaking strength.

SECTION 2.5 IDENTIFICATION / MARKING REQUIREMENTS

- 2.5.1 Each winch shall be marked or labeled with the following required information to provide a method to positively identify a winch source of manufacture;
 - a. Name and/or trademark.
 - b. Working load limit (WLL) in pounds and kilograms.
- 2.5.2 The required markings shall be visible when the winch is in use with a synthetic web tie down.
- 2.5.3 Use of the letters **lb** to designate pounds and the letters **kg** to designate kilograms and **WLL** to represent working load limit shall be acceptable.
Example: 5M, 2270 kg WLL shall indicate a 5000 pound, 2270 kilogram working load limit.
- 2.5.4 The winch should also be stamped with a lot code or user-identifiable date for traceability.

CHAPTER 3.0

STANDARD PROCEDURES FOR TESTING WINCHES

SECTION 3.1 PURPOSE

- 3.1.1 This chapter provides standard procedures for testing of winches designed to accommodate synthetic web tie downs for the purpose of securing cargo.
- 3.1.2 These tests are applicable to winches produced after this publication's date and do not preclude sale of winches already produced.

SECTION 3.2 TYPE OF TESTS

- 3.2.1 Qualification Test - Testing of a preproduction winch shall be performed to establish the breaking strength.

SECTION 3.2 TYPE OF TESTS (cont.)

3.2.2 Acceptance Test - Testing of a production winch shall be performed for the purpose of verifying the breaking strength.

SECTION 3.3 TEST PROCEDURES TO DETERMINE BREAKING STRENGTH

3.3.1 Qualification Testing

3.3.1.1 Destructive tests for each winch design shall consist of a minimum of five (5) preproduction winches. The breaking strength shall be the average of the five (5) tensile load failures.

3.3.2 Acceptance Testing

3.3.2.1 Destructive tests of two (2) production winches from each lot of two thousand (2000). The breaking strength shall be a minimum of three (3) times the manufacturer's specified working load limit.

3.3.2.2 If one of the two winches fails the test, test two more. If those two pass then the production lot shall be accepted. If either of the second set of two winches fails the test the lot shall be rejected.

3.3.3 The only time the working load limit of the winch shall be exceeded is during the testing process.

3.3.4 Testing shall be done with fixtures which simulate the load path direction for the specific winch being tested. The fixture will simulate direction of load application.

3.3.5 Winches shall be installed on applicable test fixtures. See figures 2 and 3.

3.3.6 Winches normally installed by welding may be attached to test fixtures via clamps.

3.3.7 Portable style winches with set screws should be tested with screws tightened to manufacturer's recommended installation procedures.

3.3.8 Sliding winches shall be tested in a track or channel that simulates a vehicle track or channel for which they have been designed.

3.3.9 Winches that have been painted, plated or otherwise coated during the finishing process should be tested after the coating has been applied.

3.3.10 The webbing used for testing shall have a higher breaking strength than the winch. A minimum of 72.00 inches (1830mm) of webbing should be used for testing. The mandrel shall have a minimum of two and a maximum of four wraps of webbing.

3.3.11 The tensile load shall be applied at a rate of 2 to 10 inches (50 to 250mm) per minute or 100 to 1000 lbs (45 to 450 kgs) per second until failure. The tensile load at failure is the breaking strength. Failure is the point at which additional load can not be applied.

3.3.12 Test results shall be kept on file.

3.3.13 The winch manufacturer or an independent testing laboratory shall perform the testing.

3.3.14 The test machine shall be certified annually to ASTM E4 or equivalent.

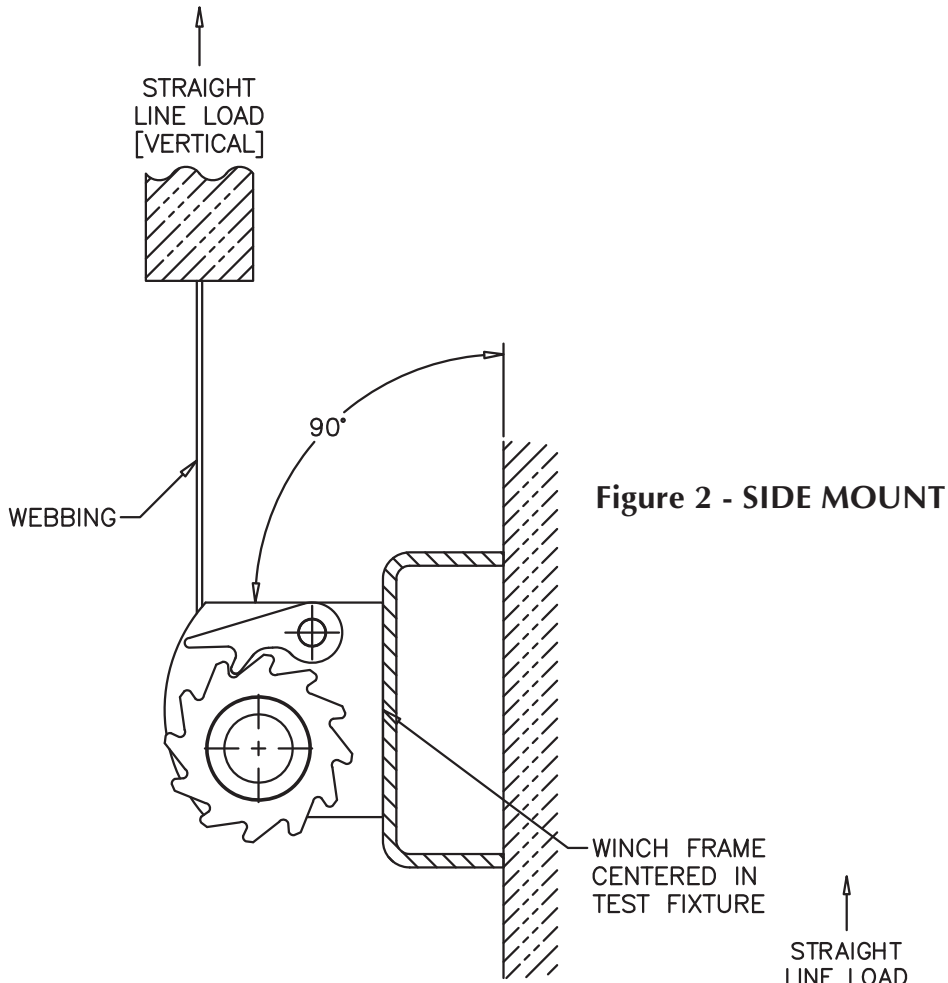

Figure 2 - SIDE MOUNT

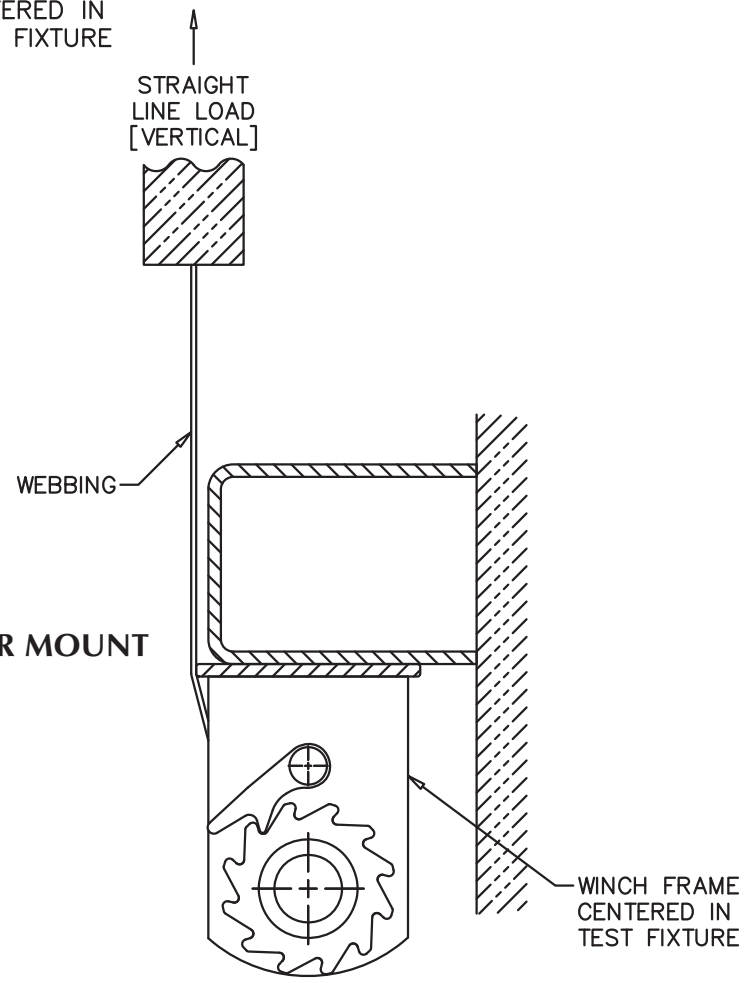

Figure 3 - UNDER MOUNT

CHAPTER 4.0

RECOMMENDED OPERATING PRACTICES

SECTION 4.1 PURPOSE

- 4.1.1 The purpose of this chapter is to provide guidelines to end users and enforcement personnel for proper selection, use and care, environmental considerations and inspection of winches used with synthetic web tie downs. These guidelines are not intended to replace proper training, experience and learned knowledge regarding proper tie down procedures when using winches.

SECTION 4.2 PROPER SELECTION

- 4.2.1 Select a winch having suitable characteristics for proper attachment to the vehicle. The winch shall have sufficient strength to properly tie down the load.
- 4.2.2 Identify the working load limit (WLL) marked on the winch by the manufacturer. If the required markings are illegible or missing, remove from service. Read all warnings and/or instructions provided by the manufacturer.

SECTION 4.3 USE AND CARE

- 4.3.1 Winches shall not be loaded in excess of the working load limit (WLL) provided by the manufacturer.
- 4.3.2 Winches shall be attached to the vehicle in accordance with the installation instructions of the winch manufacturer and vehicle manufacturer.
- 4.3.3 Winch track designed to accommodate sliding winches shall be installed per the winch track manufacturer and the vehicle manufacturer instructions.
- 4.3.4 Winches shall be installed and positioned so that the pawl is free-floating and pivots into the sprocket by gravity. A properly installed and positioned winch shall allow the user to see the pawl to ensure proper engagement.
- 4.3.5 When using any winch a minimum of two (2) and a maximum of four (4) wraps of webbing shall be on the winch mandrel. Two to four wraps will appear like four to eight layers of webbing. Less than two wraps may result in strap slippage; more than four will place unnecessary strain on the winch. Excessive wraps of webbing on the mandrel may reduce the working load limit (WLL) of the winch and may interfere with proper operation.
- 4.3.6 Before operating any winch the user shall secure his footing on the ground to prevent slipping or falling. In adverse weather conditions, including freezing temperatures, additional caution should be exercised.
- 4.3.7 Only winch bars designed to be used with winches shall be used to tension and release tie down assemblies. Exercise caution during tensioning to ensure the winch pawl fully engages into the sprocket before releasing pressure on the winch bar. Releasing a winch bar without the pawl being properly engaged can cause serious injury.
- 4.3.8 When using a winch bar designed to utilize the holes in the end cap of a winch, the tip of the winch bar shall be inserted through two holes to prevent the tip of the winch bar from slipping or damaging the winch.

- 4.3.9 Any device, commonly known as a cheater bar, that extends the length of a winch bar shall not be used.
- 4.3.10 Winches may require re-tensioning during transit to maintain proper tension.
- 4.3.11 Winches shall be used inspected and adjusted periodically during the transportation of cargo per applicable federal, state, provincial, local and industry regulations.
- 4.3.12 Set screws on portable winches are designed to position the winch while the tie down assembly is being tightened. They shall only be snug tight. Over tightening of screws may cause the bracket to bend, weakening the winch and causing it to fail.
- 4.3.13 Portable winches with or without set screws shall be removed from the vehicle frame when not being used to tension a synthetic web tie down.
- 4.3.14 Winches designed to secure cargo shall not be used for lifting, lowering or suspending cargo or for towing.

SECTION 4.4 ENVIRONMENTAL CONSIDERATIONS

- 4.4.1 Winches are subjected to dirt, mud, snow, ice, road salt, cleaning solutions, etc. Winches shall be periodically inspected, cleaned and lubricated with light oil to ensure the winch pawl will drop freely between the sprocket teeth by gravity. If this maintenance procedure does not result in the pawl dropping freely into the sprocket teeth, the winch shall be removed from service.
- 4.4.2 Winches that can be removed from the vehicle, when not in use, should be stored in a dry location.

SECTION 4.5 INSPECTION

- 4.5.1 Type Of Inspection
 - a. INITIAL INSPECTION** Designated personnel shall inspect every winch before it is placed in service to ensure that the correct winch is being used and to determine that the winch meets the requirements of this standard specification.
 - b. FREQUENT INSPECTION** The person handling the winch each time it is used shall make this inspection.
 - c. PERIODIC INSPECTION** Designated personnel shall conduct this inspection. Frequency of a periodic inspection shall be based on, but not limited to:
 - i. Frequency of use
 - ii. Severity of service conditions
 - iii. Experience gained on the service life of winches used in similar applications

SECTION 4.6 INSPECTION RECORDS

- 4.6.1 The user(s) of winches should establish written inspection records to be kept on file. These records should show a description of the winch, the condition at the time of the inspection, the date stamp on the winch if present, the date the inspection was performed, the vehicle unit number the winch is presently on and the person who performed the inspection.

SECTION 4.7 REMOVAL FROM SERVICE

- 4.7.1 A winch shall be removed from service if any of the following conditions exist:
- a. Mandrel is not free to rotate when the pawl is released
 - b. Pawl is not free to drop into the sprocket by gravity
 - c. Excessive corrosion
 - d. End cap is deformed and will not permit use of winch bar.
 - e. Distorted or deformed components
 - f. Cracks, broken or malfunctioning components
 - g. Cracked welds
 - h. Weld of winch to vehicle is cracked.
 - i. Deformed or worn winch track
 - j. Any other visible damage which causes doubt as to the strength of the winch or winch track.

SECTION 4.8 REPAIR OF WINCHES

- 4.8.1 No repairs of winches, winch components or winch track shall be permitted.

ADDITIONAL RESOURCES

U.S. Department of Transportation
Federal Highway Administration (FHWA)
Federal Motor Carrier Safety Regulations
(FMCSRs 0, Title 49 of the Code of
Federal Regulations (CFR): Sections
392.9, Safe Loading; Part 393, Subpart 1
Protection Against Shifting or Falling Cargo
Copies of 49 CFR Parts 200-399 may be
purchased from the U.S. Government
Printing Office, (202) 512-1800.
For questions concerning specific
requirements you can contact the
Federal Highway Administration,
Office of Motor Carrier Research
and Standards (HCS-10),
400 Seventh Street, SW Washington,
D.C., 20590. Telephone (202) 366-4009
FAX (202) 366-8842.

California Administrative Code:
California Highway Patrol (CHP)
Title 13: Barclays Lay Publisher,
50 California St. 18th Floor
San Francisco, CA 94111-4624
Telephone (800) 888-3600
Fax (415) 732-8861

WEB SLING & TIE DOWN ASSOCIATION, INC.
2105 Laurel Bush Road, Suite 200
Bel Air, Maryland 21015
Phone (443) 640-1070
Fax (443) 640-1031
Email: wstda@ksgroup.org
Website: www.wstda.com

Specialized Carriers & Rigging
Association **Cargo Securement On Motor
Vehicles; Steel.** Specialized Carriers &
Rigging Association, 2750 Prosperity Avenue,
Suite 620, Fairfax, VA 22031-4312.
Telephone (703) 698-0291
Fax (703) 698-0297

In Canada Contact:
The Ministry of Transportation
In Each Province.

OTHER WEB SLING & TIE DOWN ASSOCIATION PUBLICATIONS

Recommended Standard Specifications:

Recommended Standard Specifications:

Printed Books

Synthetic Web Slings	WSTDA-WS-1
Synthetic Polyester Roundslings	WSTDA-RS-1
Webbing for Synthetic Web Slings	WSTDA-WB-1
Sewing Threads for Slings & Tie Downs	WSTDA-TH-1
Synthetic Web Tie Downs	WSTDA-T-1
Winches Used With Web Tie Downs	WSTDA-T-3
Synthetic Webbing Used for Tie Downs	WSTDA-T-4
All Standards In A Three-Ring Binder	WSTDA-ASB-2006

PDF Files On CD

Synthetic Web Slings	WSTDA-SCD-WS-1
Synthetic Polyester Roundslings	WSTDA-SCD-RS-1
Webbing for Synthetic Web Slings	WSTDA-SCD-WB-1
Sewing Threads for Slings & Tie Downs	WSTDA-SCD-TH-1
Synthetic Web Tie Downs	WSTDA-SCD-T-1
Winches Used With Web Tie Downs	WSTDA-SCD-T-3
Synthetic Webbing Used for Tie Downs	WSTDA-SCD-T-4
All Standards CD - (All above on one CD)	WSTDA-ASCD-2006

Operating & Inspection Manuals

Synthetic Web Slings	WSTDA-WS-2
Synthetic Web Slings	WSTDA-WS-2-PS (pocket sized)
Synthetic Polyester Roundslings	WSTDA-RS-2
Synthetic Polyester Roundslings	WSTDA-RS-2-PS (pocket sized)
Synthetic Web Tie Downs	WSTDA-T-2

Video

Synthetic Web Sling Care & Inspection	WSTDA-WSV-1-VHS
Synthetic Web Sling Care & Inspection	WSTDA-WSV-1-CD

Illustrated Wall Chart

Inspection of Web Slings & Round Slings	WSTDA-WSWC-1
---	--------------

UV Degradation Reports

Summary Report UV Degradation	WSTDA-UV-Sling-2003
UV Degradation Mini Manual	WSTDA-UV-MM-2005
UV Degradation Report	WSTDA-UVDR-1981 (Revised 2005)

Training CD-Rom

North America Cargo Securement Standard	WSTDA-CD-TP-2003
---	------------------

Fabric Warning Labels

Nylon Web Slings	WSTDA-SW-02-N
Polyester Web Slings	WSTDA-SW-02-P
Tie Downs	WSTDA-TW-02
Round Slings	WSTDA-RSW-03

Paper Warning Sheets

Synthetic Web Slings	WSTDA-WSWS-02
Polyester Roundslings	WSTDA-RSWS-04
Tie Downs	WSTDA-TWS-97

For ordering information and prices, contact the association office or visit our website:

Web Sling & Tie Down Association, Inc.

2105 Laurel Bush Road, Suite 200
Bel Air, Maryland 21015
Phone (443) 640-1070
Fax (443) 640-1031
Email: wstda@ksgroup.org
Web Site: www.wstda.com



This Standard is available through the WSTDA. Reproduction is not permitted